

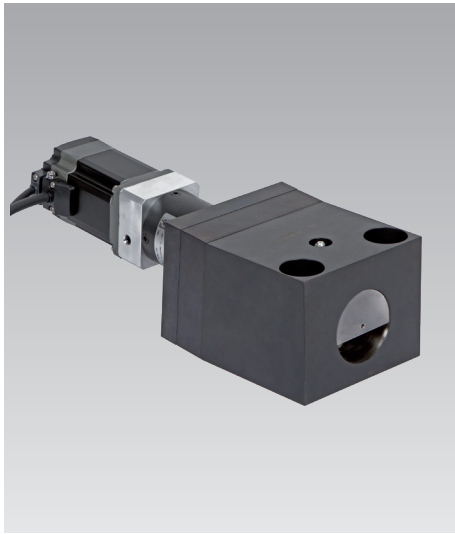

Wedge Clamps for Flat or Tapered Clamping Edge

electro-mechanical, max. operating force 240 kN
 self-locking, with position monitoring



Advantages

- Increased operating safety by mechanical self-locking and monitoring of the clamping position
- Control of the following functions: clamping and unclamping position, clamping force and speed of the clamping bolt
- Compact electro-mechanical force package
- Reclamping on the clamping point of yielding clamping edges possible
- Even in case of power failure, safe and self-locking clamped
- Optimum automation element
- High-quality corrosion protection for drive and housing

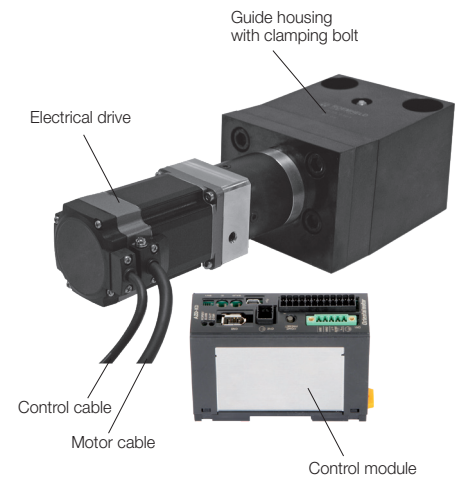

Application

Electro-mechanical wedge clamps are used for hydraulic free clamping of dies on sliding tables, in injection moulding machines and presses on bed and ram.

Application examples

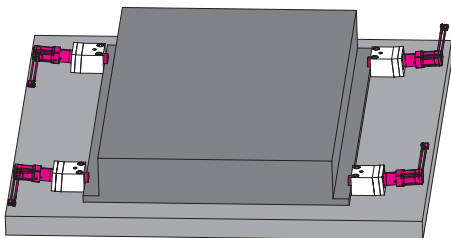

Sliding tables

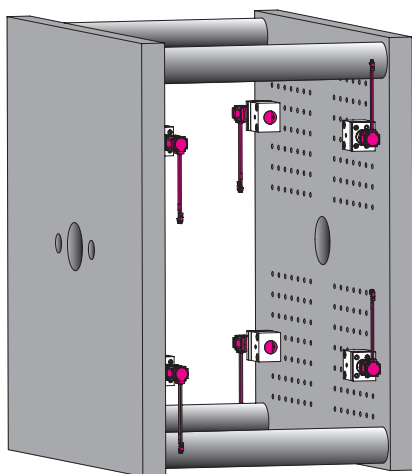

Injection moulding machines

Description

The clamping bolt of the wedge clamps is operated by a 24 VDC direct current drive via a snail transmission and a spindle stroke transmission.

The self-locking spindle lifting gear stops the drive in case of power failure and maintains it safely in the reached position.

During clamping, the clamping bolt is moved with low inclination onto the flat clamping edge. The clamping bolt is completely retracted in the guide housing in off-position.

The wedge clamp is equipped with an integrated position monitoring. In addition, fault messages can be output.

The wedge clamp is controlled via a control module equipped with different data interfaces.

Version with angular gear

By default, the electrical drive is mounted at the rear of the guide housing.

Alternatively, a version with angular gear is available. (see page 3)

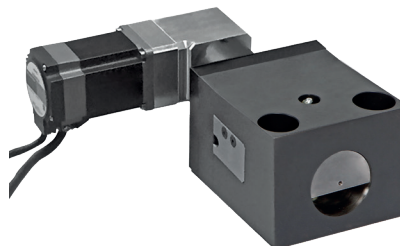

Delivery

● Wedge clamp with drive

Electrical connection:

- motor cable, firmly connected (L = 280 mm)
- control cable, firmly connected (L = 280 mm) (extension cable: see page 3)

● Control module

Position monitoring

The position monitoring is integrated in the drive. The following positions are reported on the control module:

- Clamping bolts in off-position (retracted)
- Clamping bolts in clamping position (extended)

Possible fault messages

- Outside the clamping range
- Cable break
- Current peaks
- Over temperature
- Clamping force is not reached

Possible motor variants

24 VDC stepper motors from Oriental are used. Motors from other manufacturers can also be installed on request (such as Siemens or Beckhoff).

Possible variants

- with 20° clamping bolt
- as pull or push cylinder
- as block cylinder
- as locking element
- as positioning cylinder in the range ± 0.5

Version for flat clamping edge
without angle drive / cable outlets A B C D

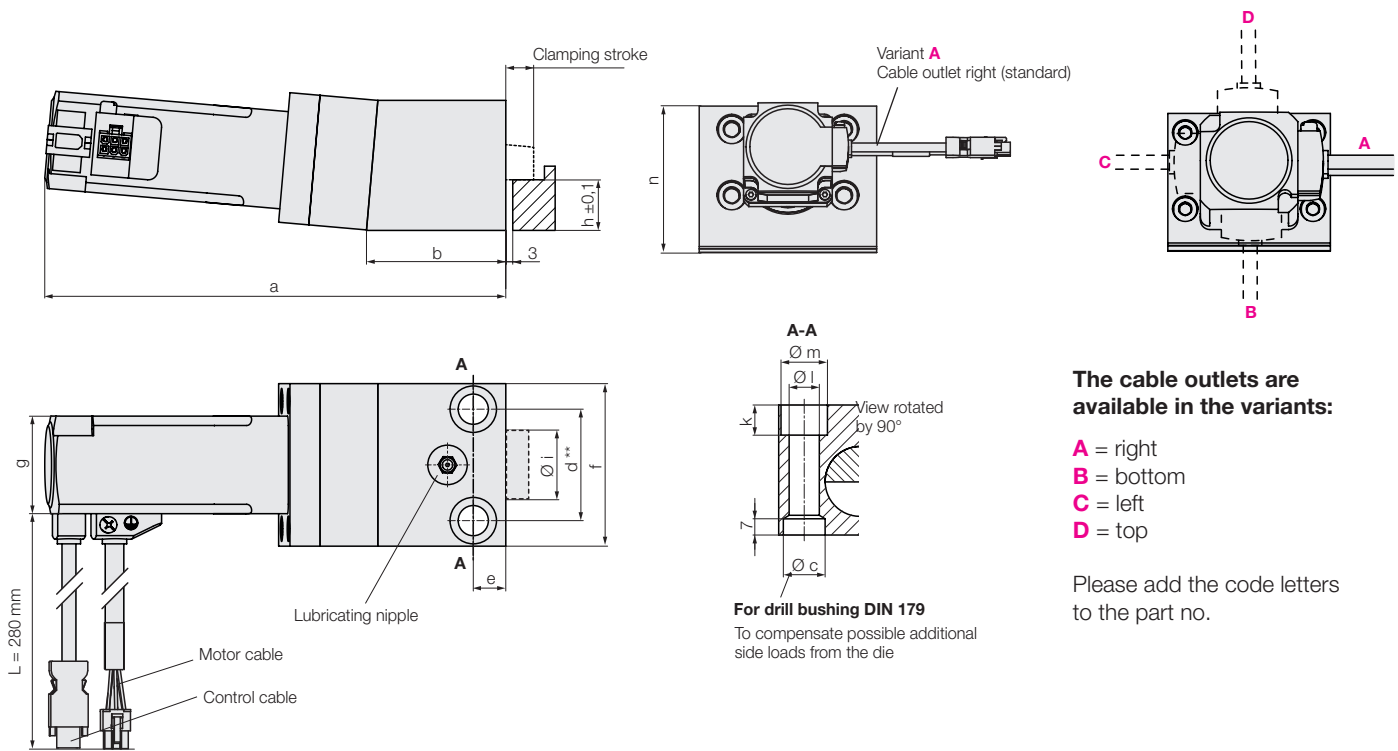

The cable outlets are available in the variants:

- A** = right
- B** = bottom
- C** = left
- D** = top

Please add the code letters to the part no.

Version for flat clamping edge without angle drive

Adm. operating force for screws 8.8 (DIN 912)	[kN]	35	60	130	190
Adm. operating force for screws 10.9 (DIN 912)	[kN]	50	90	160	240
Fastening screw		M 12	M 16	M 20	M 24
Total stroke	[mm]	20	25	25	28
Clamping stroke	[mm]	12	16	17	20
Max. temperature	[°C]	70	70	70	70
Clamping force max.	[kN]	10	20	35	35
a	[mm]	199	309	335	350
b	[mm]	60	95	109	125
Ø c H7 x depth	[mm]	18/7	26/9	30/11	35/11
d** (when using drill bushings ± 0.02)	[mm]	48	70	85	105
e	[mm]	14	16	20	25
f	[mm]	70	100	120	150
g	[mm]	55	55	73	73
h (±0.1)	[mm]	22	25	35	40
Ø i	[mm]	30	40	55	70
k	[mm]	13	17	20	26
Ø l	[mm]	13	17	21	26
Ø m	[mm]	20	26	32	40
n	[mm]	60	78	100	110
Weight	[kg]	3.3	10	15	22
Rated voltage	[V DC]	24	24	24	24
Current for empty running	[A]	1.5	1.5	1.5	1.5
Max. current	[A]	3.8	3.8	3.8	3.8
Code class		IP 54	IP 54	IP 54	IP 54
Lifting speed	[mm/s]	2	2	2	2
Part no. Cable outlet right		826730101 A	826740101 A	826750101 A	826760101 A
Cable outlet bottom		B	B	B	B
Cable outlet left		C	C	C	C
Cable outlet top		D	D	D	D

** on request also available with Euromap grid

Accessories

Drill bushings DIN 179	12 x 12	17 x 16	21 x 20	26 x 20
Part no.	3300285	3300287	3300288	3300289

Version for flat clamping edge
with angle drive / motor alignment A B C D

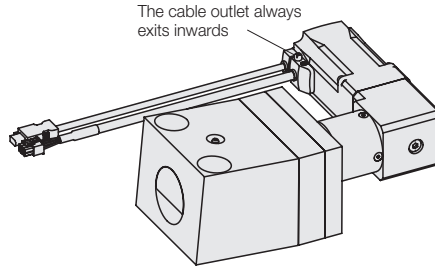
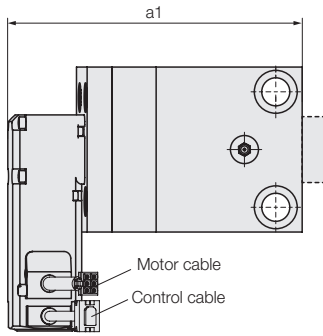

Variant with motor alignment

The motor alignment is available in the variants:

- A** = right
- B** = bottom
- C** = left
- D** = top

Please add the code letters to the part no.

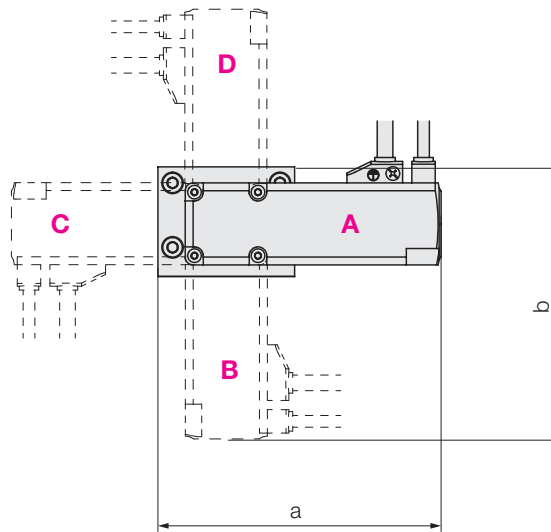

All dimensions in [mm]

Version for flat clamping edge with angle drive

Adm. operating force for screws 8.8 (DIN 912) [kN]	35	60	130	190
Adm. operating force for screws 10.9 (DIN 912) [kN]	50	90	160	240
a [mm]	145	194.5	220	235
a_1 [mm]	140	233	276	292
b [mm]	137	181	212	216
Clamping force max. [kN]	3.5	20	35	35
Part no. Motor alignment right	826730201 A	826740201 A	826750201 A	826760201 A
Motor alignment bottom	B	B	B	B
Motor alignment left	C	C	C	C
Motor alignment top	D	D	D	D

**Version for tapered clamping edge
without angle drive / cable outlets A B C D**

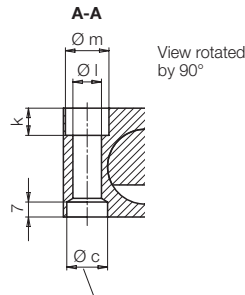
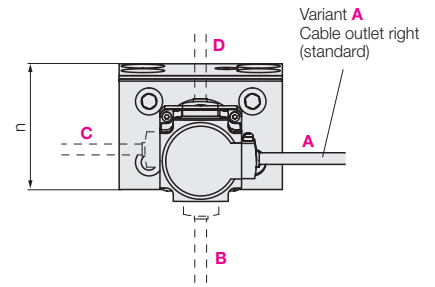
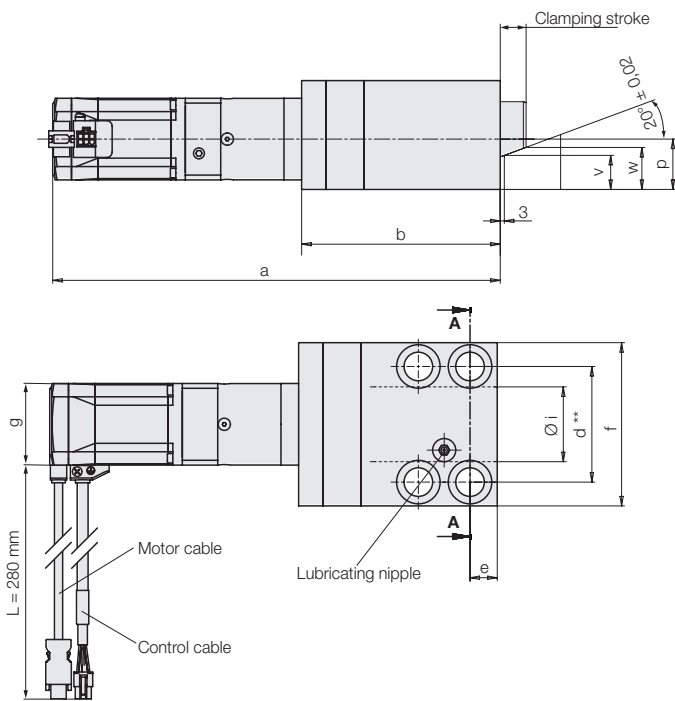

For drill bushing DIN 179
To compensate possible additional side loads from the die

The cable outlets are available in the variants:

- A** = right
- B** = bottom
- C** = left
- D** = top

Please add the code letters to the part no.

Version for tapered clamping edge without angle drive

Adm. operating force for screws 8.8 (DIN 912)	[kN]	30	50
Fastening screw		M 16	M 20
Total stroke	[mm]	25	25
Clamping stroke	[mm]	18 – 22	19 – 22
Max. temperature	[°C]	70	70
Clamping force max.	[kN]	12.5	25
a	[mm]	312	329
b	[mm]	137	146
Ø c H7 x depth	[mm]	26/9	30/11
d** (when using drill bushings ± 0.02)	[mm]	70	85
e/e1	[mm]	16/30	20/38
f	[mm]	100	120
g	[mm]	55	73
h	[mm]	67	80
Ø i	[mm]	40	55
k	[mm]	17	20
Ø l	[mm]	17	21
Ø m	[mm]	26	32
n	[mm]	67	100
p	[mm]	30	37
v (± 0.1)	[mm]	18	25
w	[mm]	23.5	30.5
Weight	[kg]	10	15
Rated voltage	[V DC]	24	24
Current for empty running	[A]	1.5	1.5
Max. current	[A]	3.8	3.8
Code class		IP 54	IP 54
Lifting speed	[mm/s]	2	2
Part no. Cable outlet right		826740102A	826750102A
Cable outlet bottom		B	B
Cable outlet left		C	C
Cable outlet top		D	D

** on request also available with Euromap grid

Accessories

Drill bushings DIN 179	17 x 16	21 x 20
Part no.	3300287	3300288

**Version for tapered clamping edge
with angle drive / motor alignment A B C D**

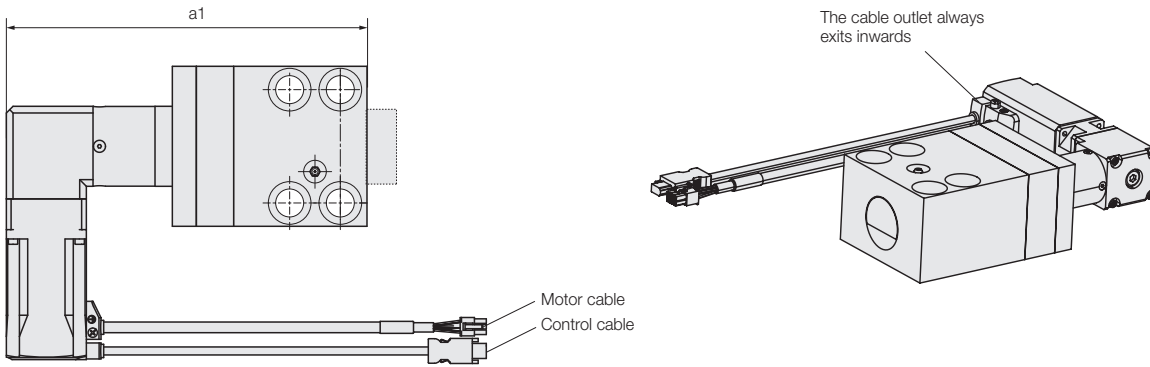

Variant with motor alignment

The motor alignment is available in the variants:

- A** = right
- B** = bottom
- C** = left
- D** = top

Please add the code letters to the part no.

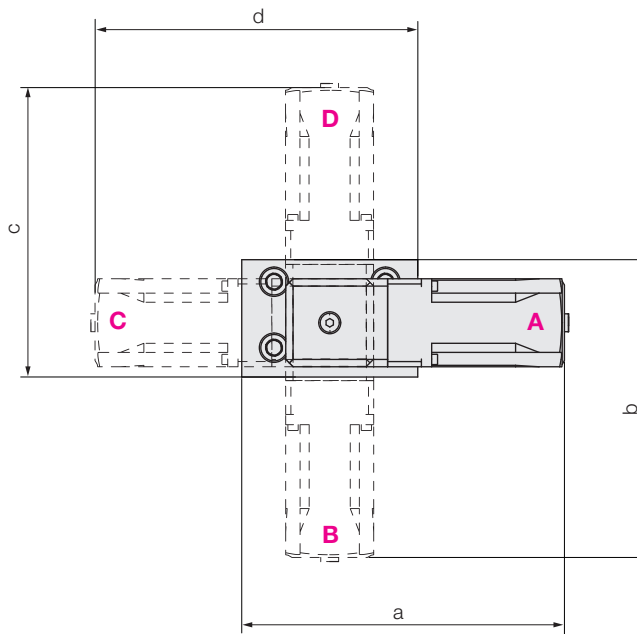

All dimensions in [mm]

Version for tapered clamping edge with angle drive

Adm. operating force for screws 8.8 (DIN 912)	[kN]	30	50
a	[mm]	194.5	220
a1	[mm]	235	270
b	[mm]	181.5	203
c	[mm]	194.5	220
d	[mm]	174.5	197
Clamping force max.	[kN]	12.5	25
Part no.	Motor alignment right	826740202A	826750202A
	Motor alignment bottom	B	B
	Motor alignment left	C	C
	Motor alignment top	D	D

Block diagram and Accessories

Wedge clamping element

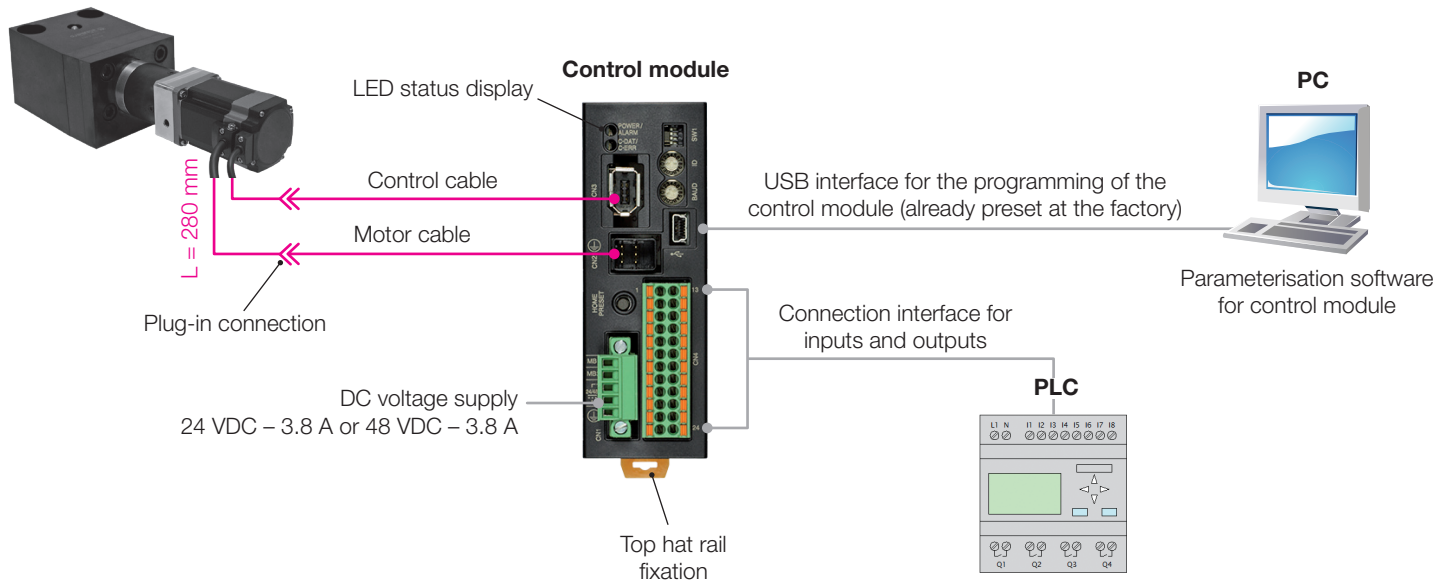

Control module

Weight: 0.15 kg

Accessory for control module

Plug for power supply electromagnetic brake
MC1.5/5-STF-3.5

Plug for input/output signals
DFMC1.5/12-ST-3.5

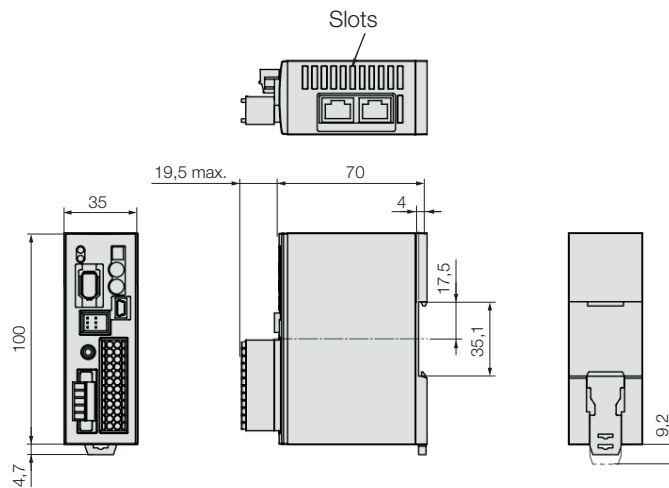

Accessories

Extension cable

Control cable and motor cable as set



Length of cable	5 m	10 m	15 m	20 m
Part no.	209750046	209750047	209750048	209750049

Options

on request

- Electromagnetic brake in the clamping element
- Drive laterally angled with angular gear
- Network-converter for CC-Link 1.1, mechatronics II and III and EtherCAT
- Ethernet/network connector RJ45 as the connection between the control modules