

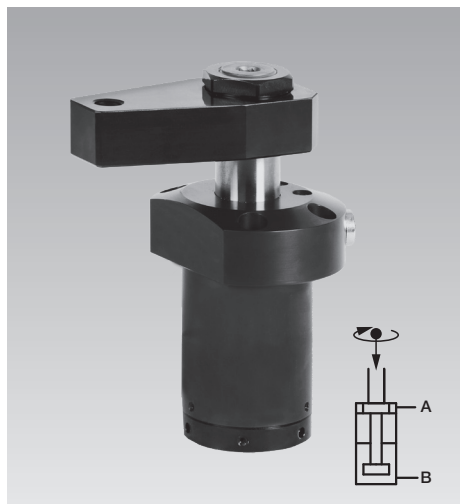

Swing clamps without swing stroke
top flange type, reinforced swing mechanism,
double acting, max. operating pressure 250 bar



Advantages

- Compact design partially recessible
- Compact design
- Extremely short clamping and unclamping times
- Swinging in into narrow recesses
- Wiper with metal swarf protection

Special features

- Reinforced swing mechanism
- Connections for pipe threads and drilled channels
- Radial anti-rotation device in the clamping stroke
- Indexing of clamping arm for repeatable alignment

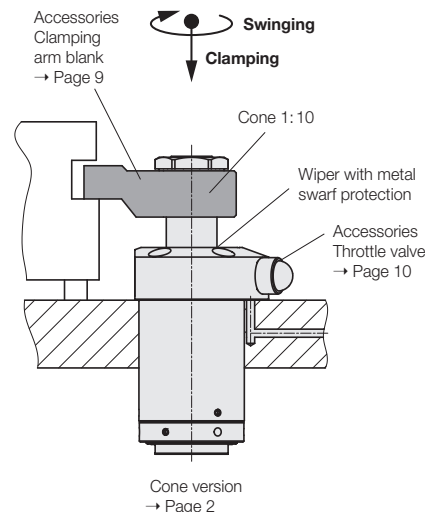

Swinging without axial swing stroke

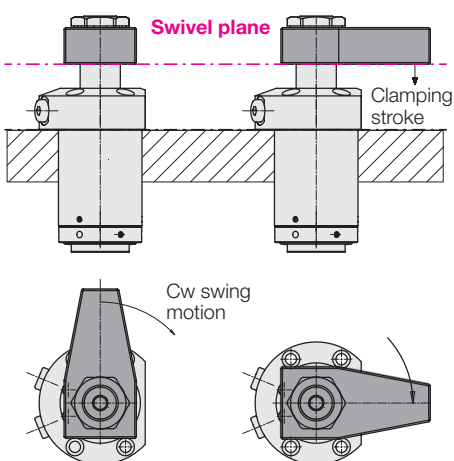

Always specify the swivel direction when viewing from above

Function

In this version without axial swing stroke, the clamping arm swivels in one plane and does not make any axial movement when swivelled.

Radial anti-rotation device in the clamping stroke

With swivelling clamping devices, workpieces can also be machined overhead. In the event of a sudden drop in clamping pressure, the radial anti-rotation device prevents the clamping arm from swivelling back. The workpiece is then no longer clamped. However, a sensible arrangement of several swing clamps and workpiece positioning aids can prevent the workpiece from falling out of the fixture (see also the note in the operating manual).

Double clamping arm

This allows space-saving clamping of workpieces in multiple clamping fixtures. Piston rods with pendulum eyes and fork heads are available so that optimally fitting double clamping arms can be attached. For a newly designed double clamping arm, the moment of inertia must be determined to calculate the admissible flow rate using the formula on page 9.

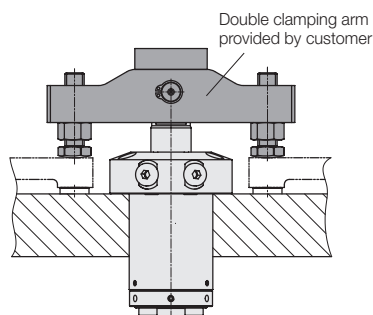

Versions

- 3 sizes
- Clamping arm seat with cone 1:10, pendulum eye or fork head
- 2 clamping strokes per size
- Clockwise, counterclockwise or non-swivelling swing motion
- Swing angle 0°, 15° to 75° and 90°
- Angle of clamping position selectable for pendulum eye or fork head

See Code for part numbers → page 8

Seals

NBR = nitrile butadiene rubber

Accessories

- Clamping arm blank
 - Throttle valve
- Page 9 and 10

Application

Hydraulic swing clamps are used for clamping of workpieces, when it is essential to keep the clamping area free of straps and clamping components for unrestricted workpiece loading and unloading.

Reinforced swing mechanism

The reinforced swing mechanism ensures that the angle position of the clamping arm remains the same even if a slight collision with the workpiece during loading and unloading or during clamping occurs.

Pendulum eye

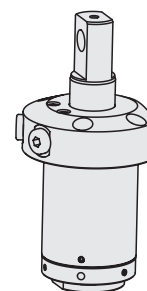

→ Page 4

Fork head

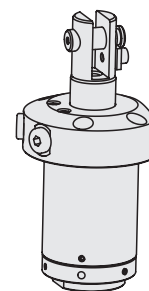

→ Page 6

Operating conditions, tolerances and other data see data sheet A 0.100.

Clamping arm seat with cone 1:10 Dimensions

Unclamping position

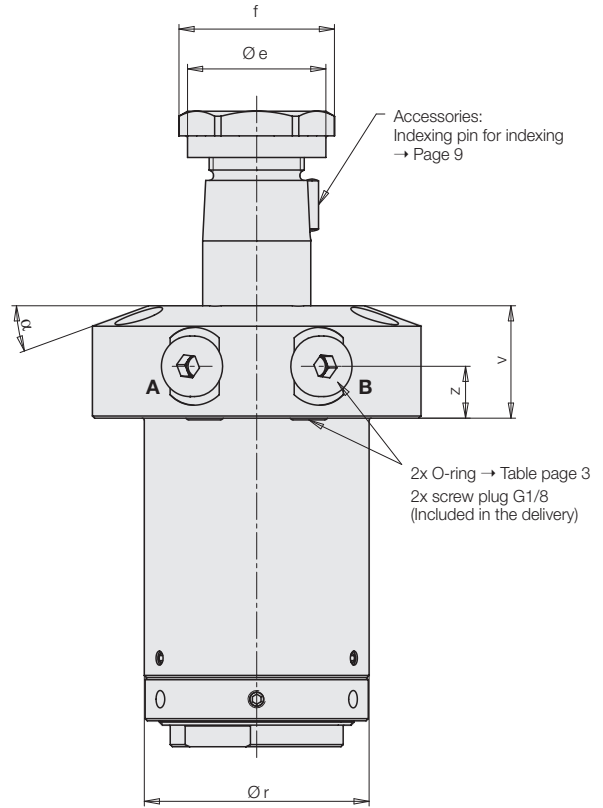
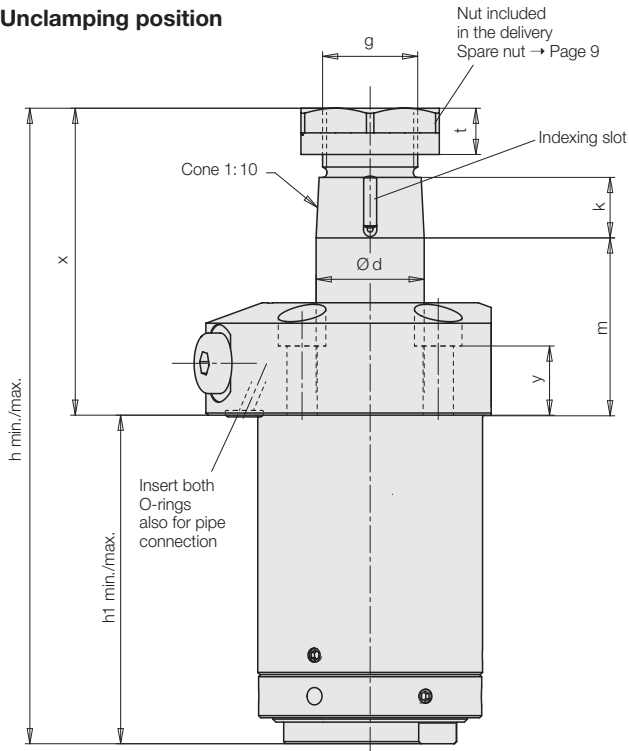

A = Clamping
B = Unclamping

Piston in clamping position

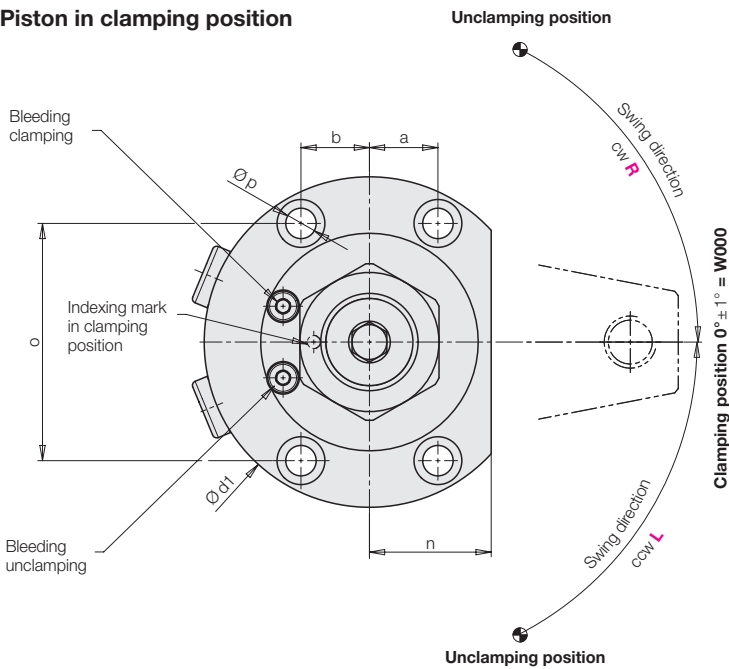

Connecting scheme

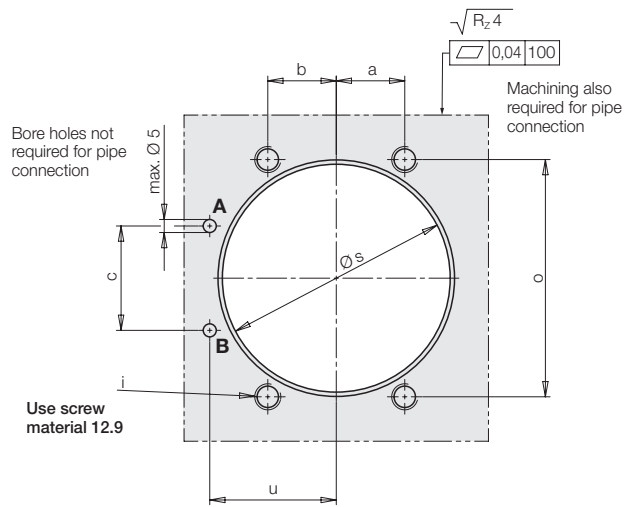

Clamping position

Angle of clamping position $W = 0^\circ$ (W000)
No other clamping position can be selected for the cone version.
The indexing mark is always opposite at 180° .

Swing angle

A swing angle of 0° , 15° to 75° in 5° increments and 90° can be selected.
Tolerance of swing angle $\pm 3^\circ$ in unclamping position

Code for part numbers and examples → Page 8

Operating conditions, tolerances and other data see data sheet A 0.100.

Clamping arm seat with cone 1:10 Dimensions and technical data

Cone 1:10		Size 1		Size 2		Size 3	
Piston/piston rod Ø	[mm]	23/16		36/25		50/36	
Clamping stroke	[mm]	8	15	12	25	12	25
Pulling force at 250 bar	[kN]	5.3		13.1		23.6	
Effective clamping force	[kN]	Diagrams see below					
Min. operating pressure	[bar]	20		20		20	
Piston ring area	[cm ²]	2.14		5.27		9.46	
Oil volume/clamping stroke mm	[cm ³]	0.21		0.53		0.95	
Oil volume/return stroke mm	[cm ³]	0.42		1.02		1.96	
Oil volume swinging 90°	[cm ³]	3.14		10.69		24.34	
Oil volume swinging 75°	[cm ³]	2.08		7.03		17.29	
Oil volume swinging 0°	[cm ³]	0.00		0.00		0.00	
Oil volume swing reduction between 75° and 15° in 5° increments	[cm ³]	0.12		0.38		1.01	
Max. adm. flow rate	[cm ³ /s]	Diagrams → Page 9					
Min. swing times	[s]	Diagrams → Page 9					
Weight, approx.	[kg]	0.8	0.9	1.9	2.3	4.6	5.4
Flange bevel α	[°]	10		20		15	
a	[mm]	11.75		15.75		22.5	
b	[mm]	11.75		15.75		22.5	
c	[mm]	18		24		34.5	
Ø d	[mm]	16		25		36	
Ø d1	[mm]	62		76		110	
Ø e	[mm]	19		32		46	
f	[mm]	27		36		53.1	
g	[mm]	M14 x 1.5		M22 x 1.5		M30 x 1.5	
h min.	[mm]	115.5	136.5	146	185	187	226
h max.	[mm]	116	137	147	186	188	227
h1 min.	[mm]	60.5	74.5	75	101	104	130
h1 max.	[mm]	61	75	76	102	105	131
k	[mm]	13.5		14		20	
i	[mm]	M5		M6		M10	
m +0.7 -0.3	[mm]	32.5	39.5	41	54	45	58
n	[mm]	19		28		38	
o	[mm]	40.7		54.56		77.94	
Ø p	[mm]	5.8		7		12	
Ø r	[mm]	36		52		72	
Ø s ±0.2	[mm]	36.4		52.4		72.4	
t	[mm]	7.5		10.7		12	
u	[mm]	21.7		29.1		41.5	
v	[mm]	22		26		28	
x	[mm]	55	62	71	84	83	96
y	[mm]	13		16		11	
z	[mm]	10		12		11	
SW	[mm]	24		32		46	
Spare O-ring	[mm]	6 x 1.5		6 x 1.5		8 x 1.5	
Part no. NBR		3000 313		3000 313		3000 343	

Effective clamping force and admissible clamping arm length

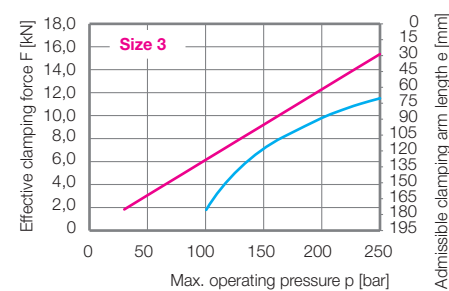
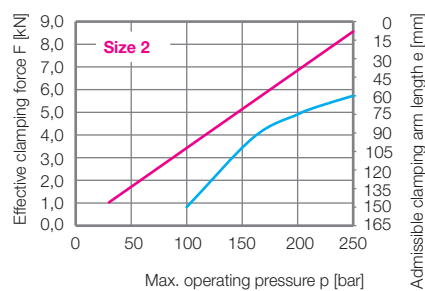
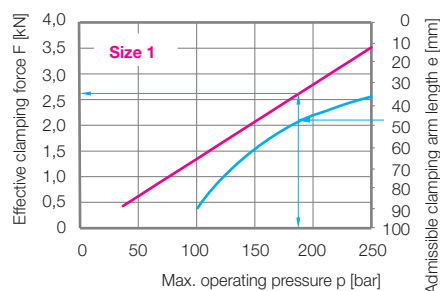

— Effective clamping force
— Admissible clamping arm length

Example:

Clamping arm length 47 mm, max. operating pressure 187 bar, effective clamping force 2.6 kN

Operating conditions, tolerances and other data see data sheet A 0.100.

Clamping arm seat with pendulum eye

Dimensions

Unclamping position

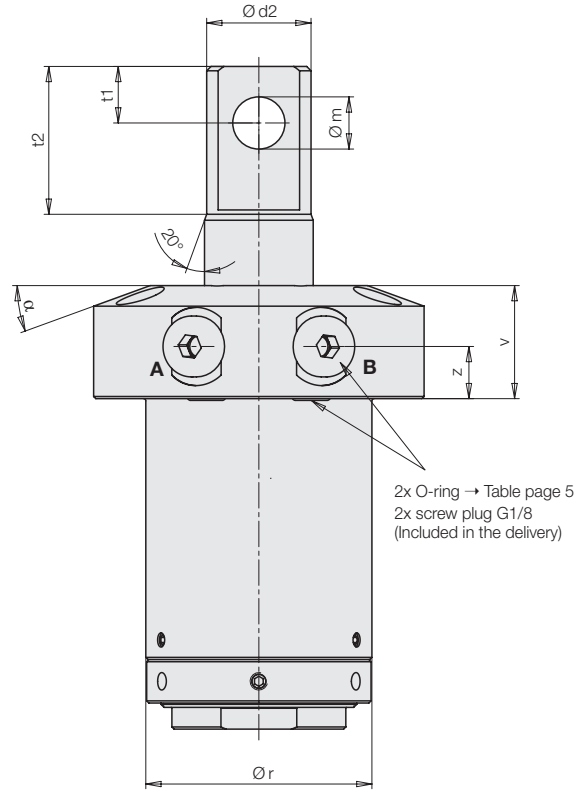
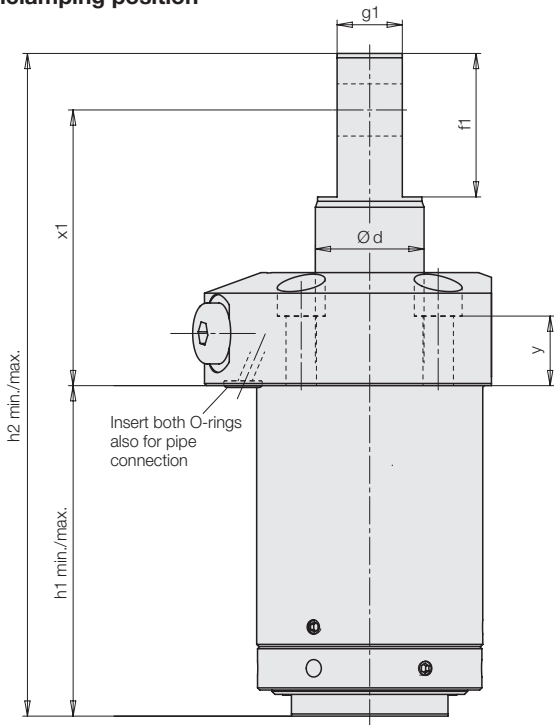

A = Clamping
B = Unclamping

Piston in clamping position

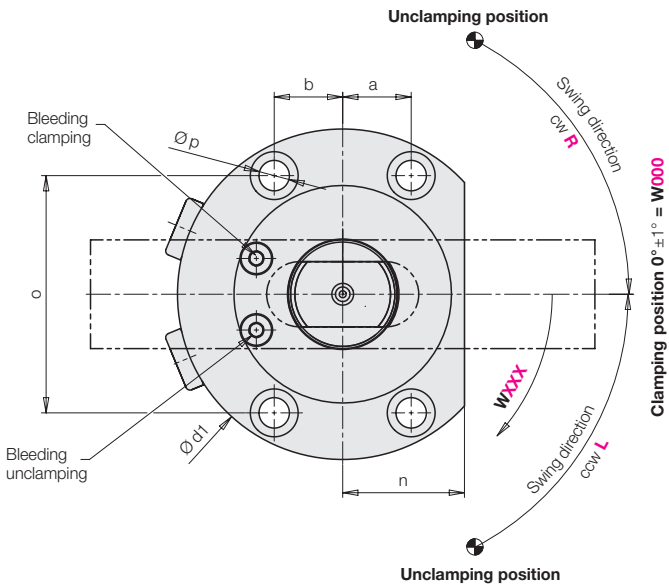

Connecting scheme

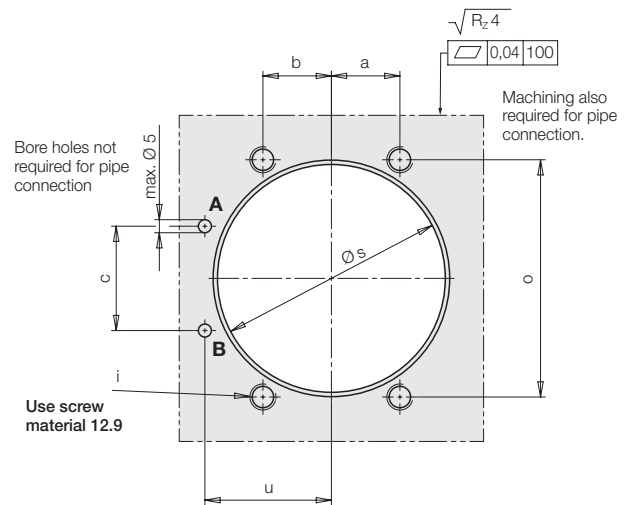

Clamping position

The angle of clamping position W can be selected between 0° and 175° in 5° increments (**W000 ... W175**).

Swing angle

A swing angle of 0° , 15° to 75° in 5° increments and 90° can be selected.

Tolerance of swing angle $\pm 3^\circ$ in unclamping position

Code for part numbers and examples → Page 8

Operating conditions, tolerances and other data see data sheet A 0.100.

Clamping arm seat with pendulum eye

Dimensions and technical data

Pendulum eye		Size 1		Size 2		Size 3	
Piston/piston rod Ø	[mm]	23/16		36/25		50/36	
Clamping stroke	[mm]	8	15	12	25	12	25
Pulling force at 250 bar	[kN]	2 x 2.65		2 x 6.55		2 x 11.8	
Effective clamping force	[kN]	Diagrams see below					
Min. operating pressure	[bar]	20		20		20	
Piston ring area	[cm ²]	2.14		5.27		9.46	
Oil volume/clamping stroke mm	[cm ³]	0.21		0.53		0.95	
Oil volume/return stroke mm	[cm ³]	0.42		1.02		1.96	
Oil volume swinging 90°	[cm ³]	3.14		10.69		24.34	
Oil volume swinging 75°	[cm ³]	2.08		7.03		17.29	
Oil volume swinging 0°	[cm ³]	0.00		0.00		0.00	
Oil volume swing reduction between 75° and 15° in 5° increments	[cm ³]	0.12		0.38		1.01	
Max. adm. flow rate	[cm ³ /s]	Diagrams → Page 9					
Min. swing times	[s]	Diagrams → Page 9					
Weight, approx.	[kg]	0.8	0.9	1.9	2.3	4.6	5.4
Flange bevel α	[°]	10		20		15	
a	[mm]	11.75		15.75		22.5	
b	[mm]	11.75		15.75		22.5	
c	[mm]	18		24		34.5	
Ø d	[mm]	16		25		36	
Ø d1	[mm]	62		76		110	
Ø d2	[mm]	15.5		24		34	
f1	[mm]	23		33		50	
g1 f7	[mm]	10		15		25	
h1 min.	[mm]	60.5	74.5	75	101	104	130
h1 max.	[mm]	61	75	76	102	105	131
h2 min.	[mm]	117.5	138.5	151.4	190.4	202	241
h2 max.	[mm]	118	139	152.4	191.4	203	242
i	[mm]	M5		M6		M10	
Ø m H7/g6	[mm]	8		12		16	
n	[mm]	19		28		38	
o	[mm]	40.7		54.56		77.94	
Ø p	[mm]	5.8		7		12	
Ø r	[mm]	36		52		72	
Ø s ±0.2	[mm]	36.4		52.4		72.4	
t1	[mm]	10		13		20	
t2	[mm]	24		34		50.5	
u	[mm]	21.7		29.1		41.5	
v	[mm]	22		26		28	
x1 +0.7 -0.6	[mm]	47	54	63.4	76.4	78	91
y	[mm]	13		16		11	
z	[mm]	10		12		11	
Spare O-ring	[mm]	6 x 1.5		6 x 1.5		8 x 1.5	
Part no. NBR		3000 313		3000 313		3000 343	

Clamping force F as a function of operating pressure p

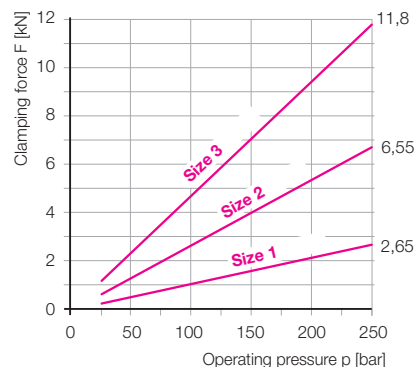
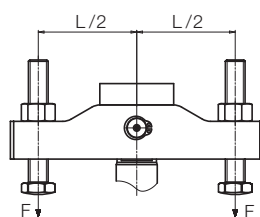

Operating conditions, tolerances and other data see data sheet A 0.100.

Clamping arm seat with fork head

Dimensions

Unclamping position

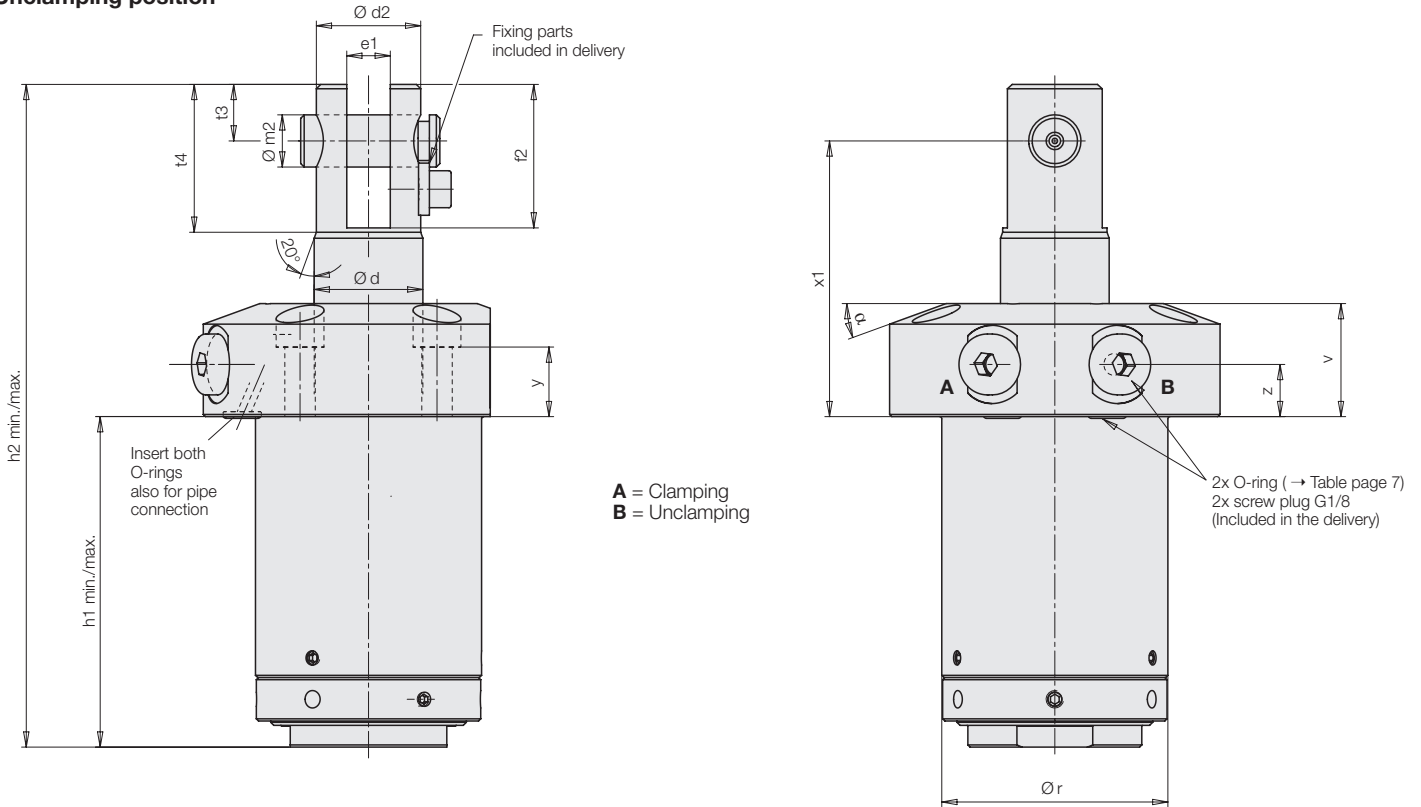

Piston in clamping position

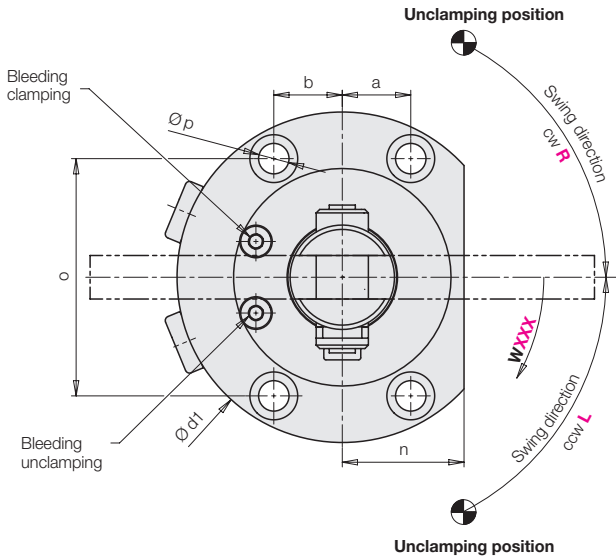

Connecting scheme

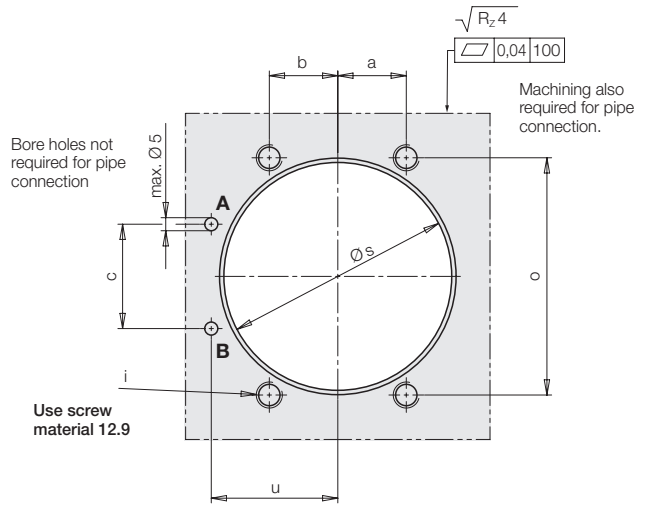

Clamping position

The angle of clamping position **W** can be selected between 0° and 175° in 5° increments (**W000 ... W175**).

Swing angle

A swing angle of 0°, 15° to 75° in 5° increments and 90° can be selected.

Tolerance of swing angle ±3° in unclamping position

Code for part numbers and examples → Page 8

Operating conditions, tolerances and other data see data sheet A 0.100.

Clamping arm seat with fork head Dimensions and technical data

Fork head		Size 1		Size 2		Size 3	
Piston/piston rod Ø	[mm]	23/16		36/25		50/36	
Clamping stroke	[mm]	8	15	12	25	12	25
Pulling force at 250 bar	[kN]	2 x 2.65		2 x 6.55		2 x 11.8	
Effective clamping force	[kN]	Diagrams see below					
Min. operating pressure	[bar]	20		20		20	
Piston ring area	[cm ²]	2.14		5.27		9.46	
Oil volume/clamping stroke mm	[cm ³]	0.21		0.53		0.95	
Oil volume/return stroke mm	[cm ³]	0.42		1.02		1.96	
Oil volume swinging 90°	[cm ³]	3.14		10.69		24.34	
Oil volume swinging 75°	[cm ³]	2.08		7.03		17.29	
Oil volume swinging 0°	[cm ³]	0.00		0.00		0.00	
Oil volume swing reduction between 75° and 15° in 5° increments	[cm ³]	0.12		0.38		1.01	
Max. adm. flow rate	[cm ³ /s]	Diagrams → Page 9					
Min. swing times	[s]	Diagrams → Page 9					
Weight, approx.	[kg]	0.8	0.9	1.9	2.3	4.6	5.4
Flange bevel α	[°]	10		20		15	
a	[mm]	11.75		15.75		22.5	
b	[mm]	11.75		15.75		22.5	
c	[mm]	18		24		34.5	
Ø d	[mm]	16		25		36	
Ø d1	[mm]	62		76		110	
Ø d2	[mm]	15.5		24		34	
e1 +0.1	[mm]	6.01		10.01		12.01	
f2	[mm]	23.5		33		50	
h1 min.	[mm]	60.5	74.5	75	101	104	130
h1 max.	[mm]	61	75	76	102	105	131
h2 min.	[mm]	117.5	138.5	151.4	190.4	202	241
h2 max.	[mm]	118	139	152.4	191.4	203	242
i	[mm]	M5		M6		M10	
Ø m2 H7/g6		8		12		14	
n	[mm]	19		28		38	
o	[mm]	40.7		54.56		77.94	
Ø p	[mm]	5.8		7		12	
Ø r	[mm]	36		52		72	
Ø s ± 0.2	[mm]	36.4		52.4		72.4	
t3	[mm]	10		13		20	
t4	[mm]	24		34		50.5	
u	[mm]	21.7		29.1		41.5	
v	[mm]	22		26		28	
x1 +0.7 -0.6	[mm]	47	54	63.4	76.4	78	91
y	[mm]	13		16		11	
z	[mm]	10		12		11	
Spare O-ring	[mm]	6 x 1.5		6 x 1.5		8 x 1.5	
Part no. NBR		3000 313		3000 313		3000 343	

Clamping force F as a function of operating pressure p

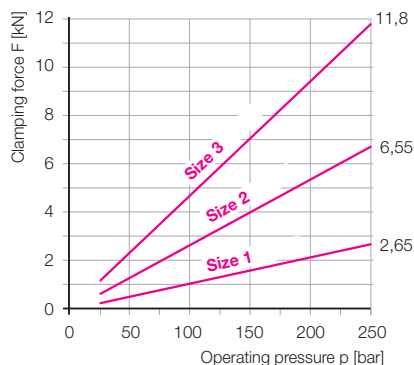
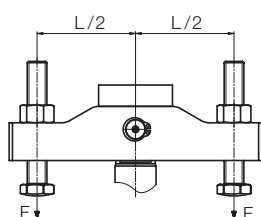

Operating conditions, tolerances and other data see data sheet A 0.100.

Code for part numbers

V1SAA X B X 5 X XXX H XXX W XXX 0 N E

Size

- D** = Size 1 (Ø23/16 – 5.3 kN)
- L** = Size 2 (Ø36/25 – 13.1 kN)
- R** = Size 3 (Ø50/36 – 23.6 kN)

Clamping arm seat

- K** = Cone 1:10 → Page 2
- P** = Pendulum eye → Page 4
- G** = Fork head → Page 6

Swing direction

- R** = clockwise
- L** = counterclockwise
- 0** = not swinging

Swing angle

- 015** = 15°
- 020** = 20°
- 025** = 25°
- 030** = 30°
- 035** = 35°
- 040** = 40°
- 045** = 45°
- 050** = 50°
- 055** = 55°
- 060** = 60°
- 065** = 65°
- 070** = 70°
- 075** = 75°
- 090** = 90°
- 000** = 0° (not swinging)

Angle of clamping position

- For cone 1:10
000 = 0°
- For pendulum eye and fork head
000 to **175** = 0° to 175°
in graduation of 5°

Clamping stroke

- For size 1 (**D**)
008 = 8 mm
015 = 15 mm
- For sizes 2 and 3 (**L** and **R**)
012 = 12 mm
025 = 25 mm
- Clamping stroke limit upon request

Ordering example 1

- Size 2 = **L**
- Cone 1:10 = **K**
- Cw swing motion = **R**
- Swing angle 75° = **075**
- Clamping stroke: 12 mm = **012**
- Clamping position 0° = **000**

Part no.
V1SAA L BK5 R075 H012 W000 0NE

Ordering example 2

- Size 1 = **D**
- Pendulum eye = **P**
- Cw swing motion = **R**
- Swing angle 75° = **075**
- Clamping stroke: 8 mm = **008**
- Clamping position 30° = **030**

Part no.
V1SAA D BP5 R075 H008 W030 0NE

Ordering example 3

- Size 3 = **R**
- Fork head = **G**
- Ccw swing motion = **L**
- Swing angle 75° = **075**
- Clamping stroke: 25 mm = **025**
- Clamping position 160° = **160**

Part no.
V1SAA R BG5 L075 H025 W160 0NE

Unclamped

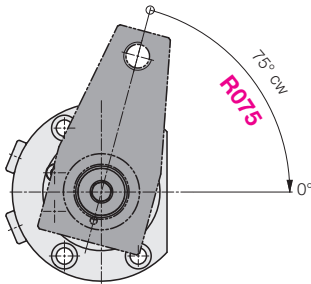

Unclamped

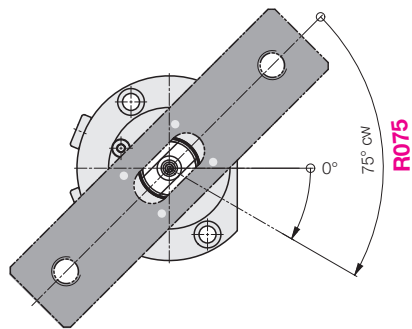

Unclamped

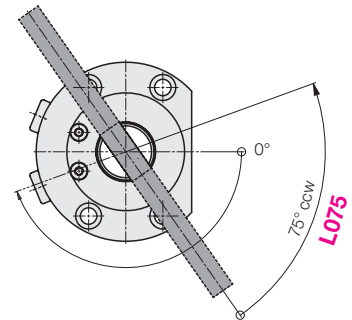

Clamped

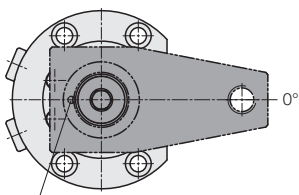

Indexing mark
in clamping position **W000**

Clamped

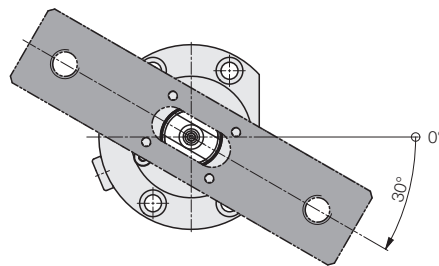

W030

Clamped

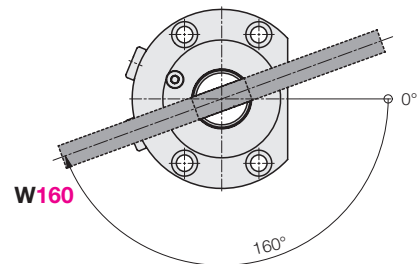

W160

Cone 1:10 • Accessories

Clamping arm blank

Clamping arm blank for swing clamps

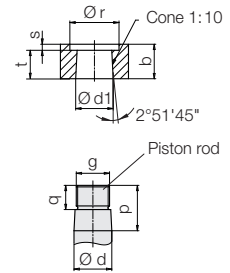
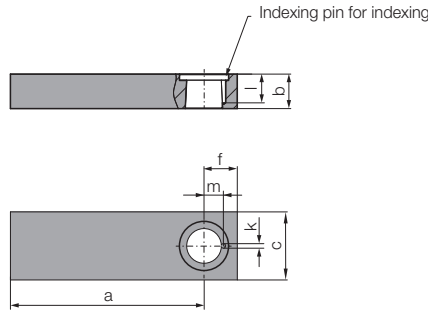
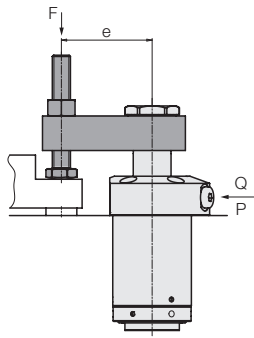

The cone seat is part of the clamping arm blank with the required precision. Adapting to the workpiece clamping points is achieved by

- Shortening to the required clamping arm length
- A thread for a hardened contact bolt, which can also be adjustable
- Beveling on the sides and top/bottom for better swarf flow and to reduce the mass moment of inertia

Moment of inertia of the clamping arm

To prevent the swing mechanism from overload, the swing speed must be reduced by throttling the flow rate depending on the moment of inertia of the clamping arm in use (see Accessory Throttle valve → page 10).

Diagram of swing time

This is based on a short standard clamping arm with a moment of inertia J_e and a swivel time of 1 second.

Calculation of the 90° swing time:

$$t_{\min} = 1 \text{ s} \cdot \sqrt{\frac{J_L}{J_e}} \geq 1 \text{ s} \quad [\text{s}]$$

Calculation of the admissible flow rate:

$$Q_{\text{adm}} = Q_e \cdot \sqrt{\frac{J_e}{J_L}} \leq Q_e \quad [\text{cm}^3/\text{s}]$$

Q_e = max. flow rate for the standard clamping arm according to table [cm³/s]

J_e = moment of inertia of the standard clamping arm according to table [kg · mm²]

J_L = moment of inertia of the desired clamping arm [kg · mm²]

Type		BG1 (V1SA ADB)	BG2 (V1SA ALB)	BG3 (V1SA ARB)
a	[mm]	90	150	175
b	[mm]	17	22.8	29.5
c	[mm]	28	45	60
Ø d f7	[mm]	16	25	36
Ø d1 -0.05 / -0.1	[mm]	16	25	36
e max. at 250 bar	[mm]	35	60	70
f	[mm]	16	22	30
g	[mm]	M14 x 1.5	M22 x 1.5	M30 x 1.5
Ø k +0.05	[mm]	3	3	4
l +0.5	[mm]	9.5	18	18
m ±0.05	[mm]	7.8	12.8	17.5
p	[mm]	22.5	30	38
q	[mm]	9	16	18
Ø r	[mm]	20	32.5	47
s	[mm]	2.5	4	4
t	[mm]	15	19.3	26
Weight	[kg]	0.37	1.29	2.6
Moment of inertia of J_e	[kg · mm ²]	936	9292	25694

Part no.

Clamping arm blank	3548 4215	3548 4216	3548 4217
--------------------	-----------	-----------	-----------

Spare nut

Tightening torque	[Nm]	16	50	110
-------------------	------	----	----	-----

Dowel pin

	[mm]	Ø3x6	Ø3x12	Ø4x12
--	------	------	-------	-------

Short standard clamping arm

Max. flow rate Q_e	[cm ³ /s]	3.14	10.69	24.34
Moment of inertia of J_e	[kg · mm ²]	100	1450	3250
Min. swing time	[s]	1	1	1

Moment of inertia

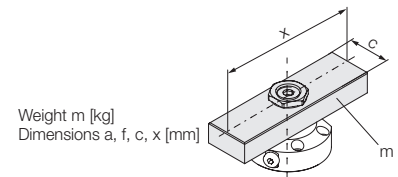
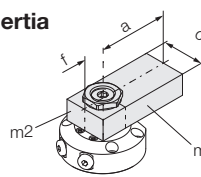

$$J_L = m_1 \frac{4a^2 + c^2}{12} + m_2 \frac{4f^2 + c^2}{12} \quad [\text{kg} \cdot \text{mm}^2]$$

$$J_L = m \frac{x^2 + c^2}{12} \quad [\text{kg} \cdot \text{mm}^2]$$

Min. swing time and admissible flow rate dependent on the moment of inertia of the clamping arm

Illustrations valid from swing angle 15°

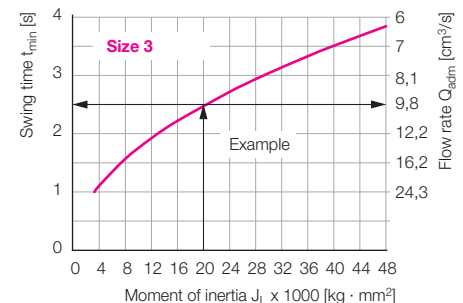
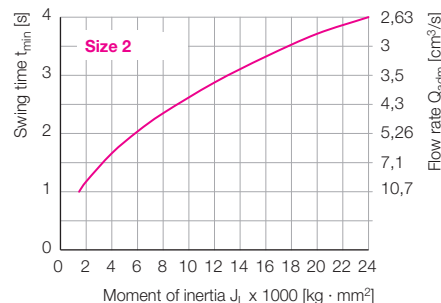
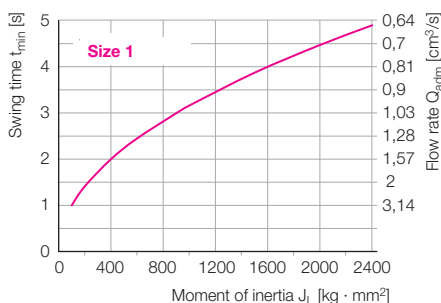

Max. operating pressure depending on the clamping arm length e → Page 3

Operating conditions, tolerances and other data see data sheet A 0.100

Example: $J_L = 20.000 \text{ kg} \cdot \text{mm}^2$
 $\rightarrow t_{\min} = 2.5 \text{ s} \rightarrow Q_{\text{adm}} 9.8 \text{ cm}^3/\text{s}$

Accessories

Throttle valve

Application

These throttle valves are used

- in order to reduce the swing speed of the clamping arm
- in order to improve the synchronism of several swing clamps

Important notes

This application is only possible when using drilled ducts as connections because the throttle valves are screwed into the existing G1/8 pipe connections.

In the case of strong throttling, increasing back pressure upstream of the throttle valve can trigger premature switching of pressure switches and sequence valves.

Dimensions

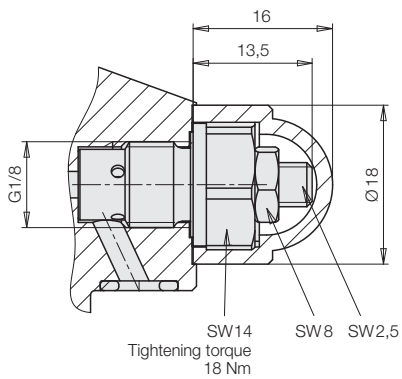

Weight 0.025 kg

Part no. 2957 209

Hydraulic symbols

