

R-MAG-R Magnetic Clamping System for Rubber Moulding Presses

Operating temperature up to 230 °C



Vertical application



Horizontal application

Application

R-MAG-P magnetic clamping systems are primarily used for automatic clamping of different dies on rubber presses.

Description

With magnetic clamping systems, the moulds are magnetically clamped or unclamped at the push of a button within a few seconds.

Since permanent magnets generate the force of the magnetic clamping plates, electric clamping is only required to magnetize the plates.

The magnetic clamping plates are de-energized in clamped condition and thus absolutely safe in case of power failure.

Additionally, the complete clamping cycle is monitored by different sensors, thus guaranteeing reliable die clamping.

Scope of system and delivery

R-MAG-R magnetic clamping systems are delivered as complete clamping systems with all required system components. The essential components of a system are:

- two magnetic clamping plates
- electric control in a splash-proof control box
- A manual remote control
- required electrical connection cables

Customised versions

All R-MAG magnetic clamping systems are customized and manufactured to meet specific requirements.

For example, the size and pole arrangement of the magnetic clamping plates are selected according to the application and the machine. Please contact us.

Technical Data

Size of the magnetic clamping plates		Customised
Pole technology		Long pole
Max. temperature	[°C]	230
Effective magnetic force	[kg/cm ²]	5–12
Magnetic penetration depth	[mm]	20
Plate thickness	[mm]	min. 55

* force directly on the magnet

Advantages

- **QUICK** – Dies are clamped in one second at the touch of a button
- **PROFITABLE** – Setup cost optimization from die change that takes only a few minutes
- **FLEXIBLE** – Die standardization no longer required
- **ERGONOMIC** – Safe die handling with ease
- **RELIABLE** – Distortion-free and full-surface retention force even if power fails
- **SAFE** – Various sensors monitor the entire clamping cycle

Safety functions

- The inductive limit switch checks for form-fit contact of the die and guarantees clamping without force loss.
- Sensors inside the coils register the slightest die movements due to changes in the magnetic flow between the magnetic clamping plate and die.
- A temperature sensor in the magnetic clamping plate prevents overheating and thus damage to the system.

Installation on a rubber press

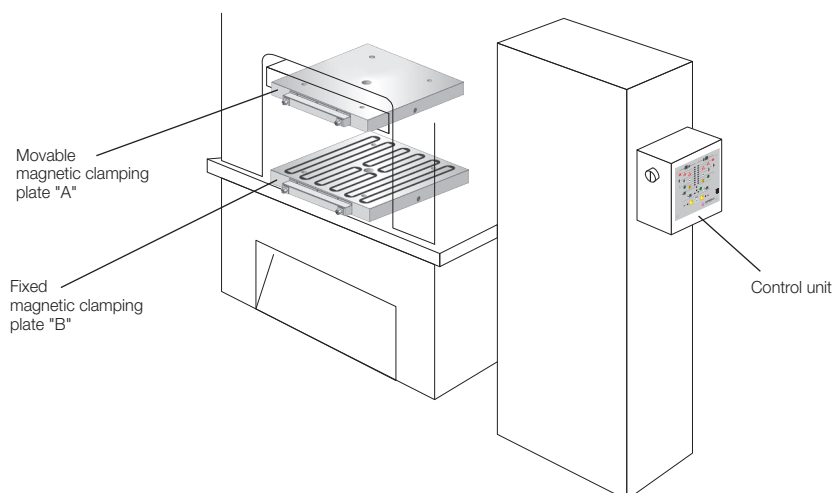

Function of the magnetic clamping plates

The electro-permanent magnetic clamping system is also firmly kept in place if the power fails. Power is only required for approx. 1 to 2 seconds to magnetize the system. After that, the clamping system works independently of any power supply. The magnetic clamping force is exclusively generated by the permanent magnets. Only when the mould is unclamped is electrical energy required again (1–2 seconds) to demagnetize the clamping plate. An existing AlNiCo magnet in the core is reversed in polarity by a current pulse. This magnet affects the magnetic field and relocates it completely to the interior of the magnetic clamping plate (demagnetized) or approx. 20 mm outside the plate (magnetized).

Demagnetized

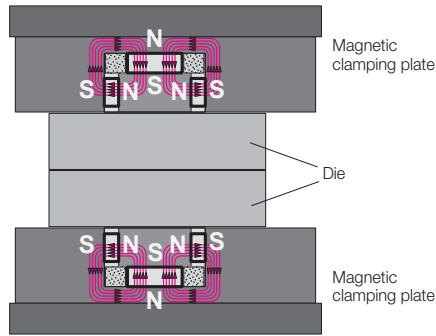

Magnetized

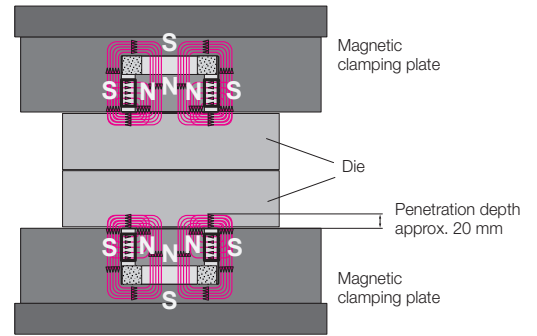

Magnetic clamping plate design

1. The fixing grid is designed to align with the existing bore holes to the greatest extent possible.
2. The mechanical limit switch checks for perfect contact of the die and then releases the magnetization.
3. Optional slots for roller or ball bars (also part of the ROEMHELD Group product range) can be inserted in the lower magnetic clamping plate to simplify die change.

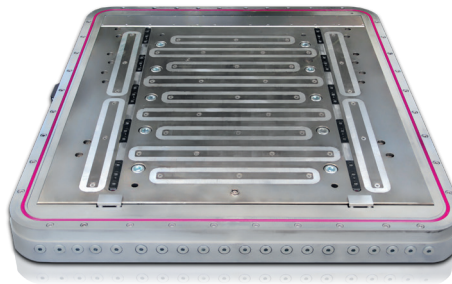

Other safety devices in the plate:

- Sensors inside the coils respond to induction and report the slightest die movements.
- A temperature sensor in the magnetic clamping plate prevents overheating and thus damage to the system.

Power concentration of long pole technology

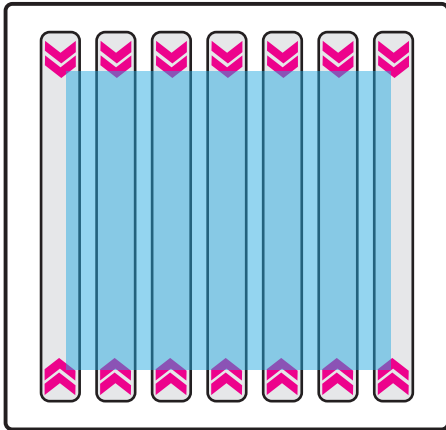

The magnetic field lines of the partially covered poles act in addition to the completely covered poles on the die and enable safe clamping of the smallest dies.

Electric control



- Highest safety standards as per EN201 and EN289
- Control via remote control or machine panel
- Simple error diagnosis via readout
- Easy and safe operation
- IP54 splash-proof
- Error code indication on the LCD display
- Lacquering in preferred colour
- Integration via EUROMAP interface
- Easy to maintain with exchangeable master module
- Key switch protects from unauthorized operation



Heating elements

Integrated heating elements combine heating and clamping in a single process. Changing and clamping dies in heated condition are simplified, and the risk of injury is reduced.

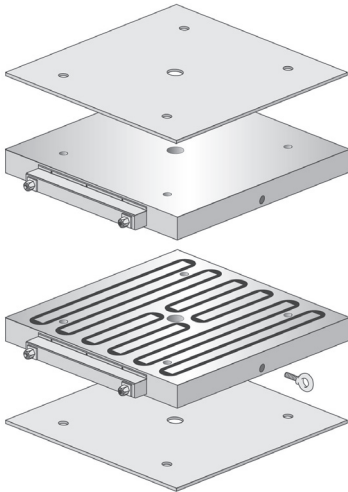

Insulation plates

The insulation plates are mounted between the machine table and the magnetic clamping plates. They enable uniform heat distribution and prevent heat from passing from the die to the machine.

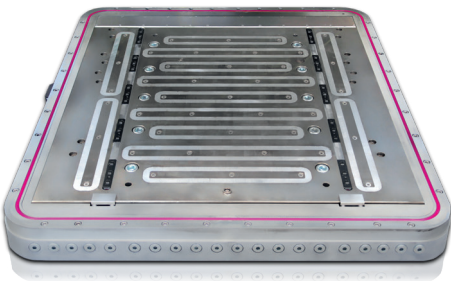

Vacuum version

The special sealing of the coils and cable exits is designed for vacuum applications in productions with the highest quality requirements.

Wedge clamping elements in hydraulic or electric versions

Data sheet WZ 2.2450



Data sheet WZ 2.2451

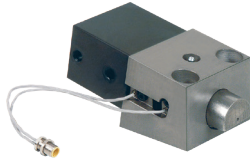

Data sheet WZ 5.2670

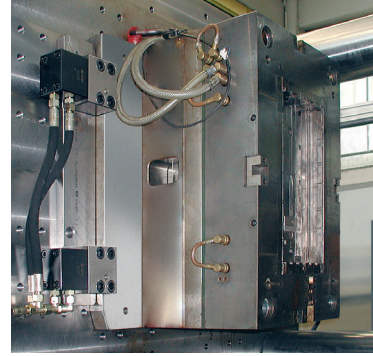

Roller or ball bars

Roller and ball bars in the lower magnetic clamping plate allow easy and trouble-free die change and prevent damages to the surface.

Data sheets WZ 8.18340 – 8.18347

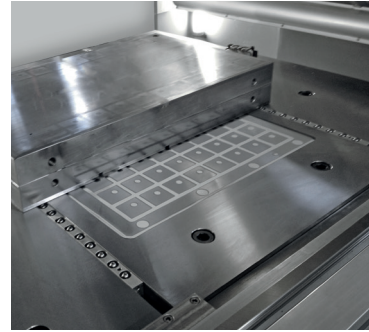

See roller and ball bar configurator:
<https://www.roemheld-gruppe.de/productconfigurator/?lang=en>

Driven die changing systems

Data sheet WZ 8.18362



Combination of push chain direct system with standard carrying console

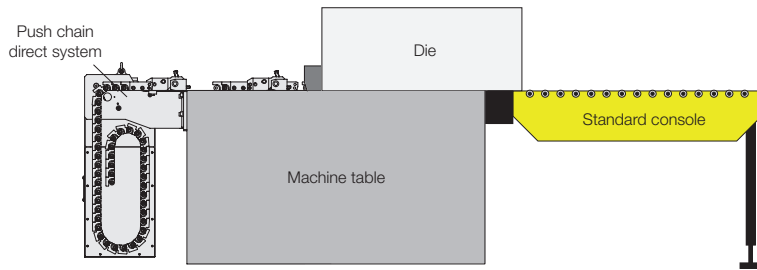

Die changing carts and carrying consoles

Data sheet WZ 8.8900



Data sheet WZ 8.8904

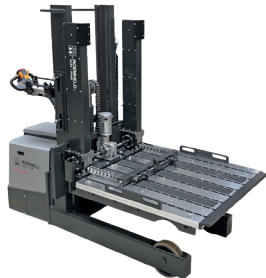

Data sheets WZ 8.18350 – 8.18354

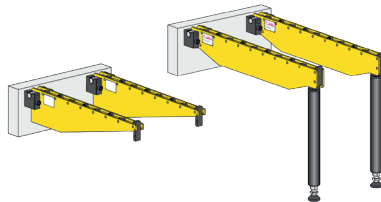

Discover the QDC app now!

<https://wz-app.roemheld.de/en/home>



Magnetic clamping systems also available for:

- Sheet metal forming
- Plastics industry
- Rubber moulding presses
- Mould carriers
- Die casting machines